

Technical data sheet

CARLA 2021 eCARLA 2021

TABLE OF CONTENT

1. CARLA 2021
 1. Dimensions and weight of the trailer
 2. Dimensions of the loading area
 3. Dimensions and weight of the load
 4. Light and reflectors
 5. Material and attachments
 6. Product photos
2. eCARLA 2021
 1. General parameters
 2. AES (48V)
 3. Greenpack (48V)
3. Technical drawing
4. Technical informations

1 PRODUCT OVERVIEW CARLA 2021

1.1 DIMENSION AND WEIGHT OF THE TRAILER

Length	Without drawbar	2300 mm
	With drawbar	3050 mm
	Drawbar screwed in, minimum length	2100 mm
Width	Width at the rear suspension	970 mm
Height	Unloaded at the drawbar	ca. 800 mm ₁
Ride height	Off ground	ca. 150 mm ₁
Net weight	With floor plate	ca. 42 kg
Position of the wheel axles	Measured from the back	650 mm
Turning circle load trailer		2100 mm

1.2 DIMENSION OF THE LOADING AREA

Loading area 4x Euronorm boxes (60x40 cm)	Length	1650 mm
	Width	650 mm
Height	Of the platform surface from the ground	ca. 170 mm ₁
	The side railing	150 mm
	Of the lateral mudguards via platform	400 mm

1.3 DIMENSIONS AND WEIGHT OF THE LOAD

Load capacity		200 kg
Volume capacity		ca. 1,50 m ³
Load height	Off the ground	Ca1600 mm ₁
	From the platform	1400 mm

1.4 LIGHT AND REFLECTORS



Light	Back	Option Busch + Müller: Hub dynamo / 2 x LED-Rearlight / Standlight Option SON (for CARLA only): Hub dynamo / 2 x LED-Rearlight
	Front	Two pieces
Reflectors	Back	Two pieces
	Front	Two pieces
	At the side	Integrated in tyres

¹dependent on load and tire pressure.

1.5 MATERIAL AND ATTACHMENTS

Frame	Material	Steel tube frame, own construction (robot welded)
	Colours	Standard: Sun Yellow RAL 1037 Standard: Deep black RAL 9005
		RAL colours on customer request
Floor plate		9 mm Screen-printed plywood, waterproof - with engraving
Bicycle fork		Steel pipe, own construction
Overrun brake with brake booster		Own construction
Brakes	Back wheels	Option mechanical: Rever (MCX-2(PM)) or Shimano (BR-M375) Option hydraulic: Magura (BIG Twin)
	Front wheels	Mechanical rim brake, parking function
Tyres	Wheel rims	20 Zoll Cavity rims
	Mantle	Schwalbe (Big Ben / Pick Up)
Drawbar		Steel pipe, own construction
Clutch		Haerry-clutch, short execution
Safety flag		Rod 1450 mm / Flag with logoprint

1.6 PRODUCT PHOTOS

		
<ul style="list-style-type: none"> • Handle of the handcart • Parking brake on the handcart • Counterpart of the clutch • Electronic connections* (Pedal sensor, throttle handle) 	<ul style="list-style-type: none"> • Rim brake • Drawbar • Overrun brakes • Battery holder* (standard model) • Electric engine* 	<ul style="list-style-type: none"> • Rear wheels suspension • Disk brakes of the overrun brake • Back lights and reflectors • Mudguards

* Pictures show an eCARLA

2. PRODUCT OVERVIEW eCARLA

The eCARLA is based on the basic model and differs in terms of electrification. It is delivered without battery and charger as standard. The eCARLA is prepared according to the selected battery (battery holder, etc.). A later switch between the two battery sizes is **not** possible.

2.1 GENERAL PARAMETERS

Operating modes	Bicycle	Support up to 25 km/h
	Handcart	Support up to 6 km/h
Pedal sensor	Pedal sensor at the bottom bracket. Depending on the bottom bracket there are different versions, we are happy to advise you	
throttle handle	At the Trailer	Handcart up to 6 km/h
	At the bicycle	Starting assistance up to 6 km/h
		Additional boost up to 25km /h

2.2 eCARLA AES (48V)

Drive unit	Engine	Bafang G070.500.D13
	Peak performance nominal	500 W
	Nominal performance (according DIN EN 15194)	250 W
	Torque	45 Nm
Battery	Model	AES eBike Akku 2.0
	Capacity	720 Wh
	Range	40 – 50 km ₂
	Charging time	ca. 7,5 h
	Weight	5,9 kg
	Exchangeable	yes
	Cell type	LiFePo4
	Lockable	no
Battery charger		IN: 100-240V: 50Hz~60Hz
Weight	Total with motor and battery	ca. 51 kg

2 Data without guarantee, highly dependent on load and gradient.

2.3 eCARLA GREENPACK (48V)

Drive unit	Engine	Bafang G070.500.D13
	Peak performance nominal	500 W
	Nominal performance (according DIN EN 15194)	250 W
	Torque	45 Nm
Battery	Model	GreenPack
	Capacity	1400 Wh
	Range	60 – 90 km ₂
	Charging time	ca. 6 h
	Weight	9,8 kg
	Exchangeable	Yes
	Cell type	Li-Ion
Lockable	yes	
Battery charger		IN: 207-253V: 47Hz~63Hz
Weight	Total with motor and battery	ca. 55 kg

2 Data without guarantee, highly dependent on load and gradient.

3. TECHNICAL DRAWING

TECHNICAL DRAWING CARLA CARGO CARGO BIKE TRAILER

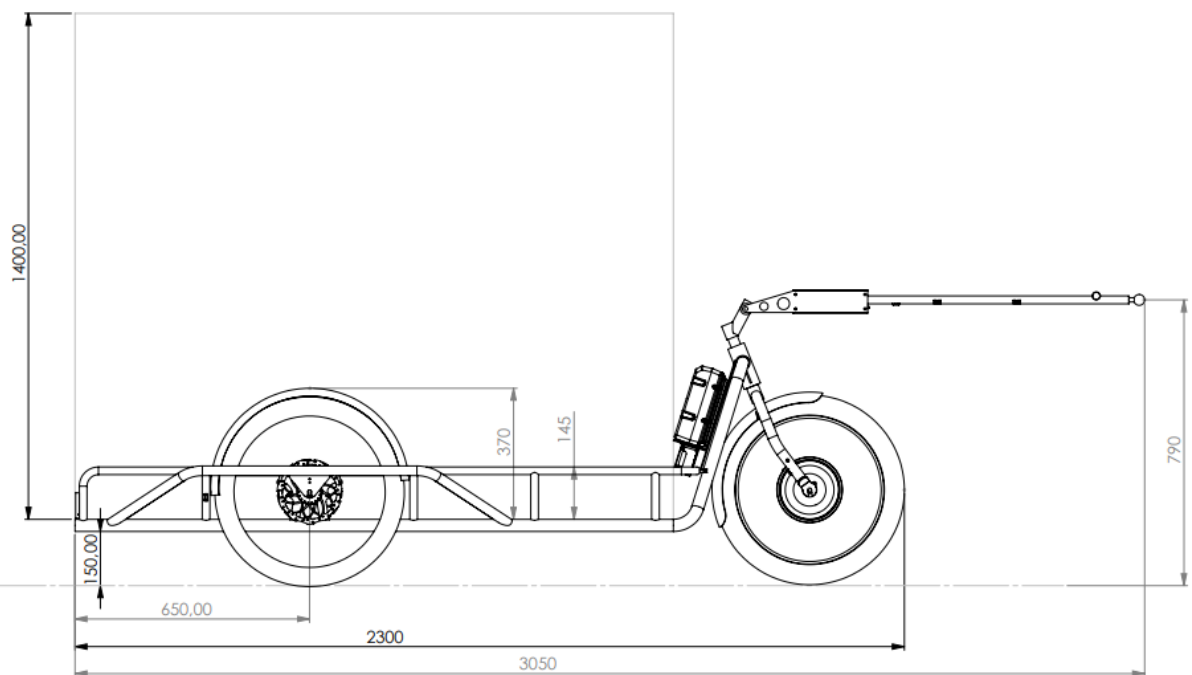
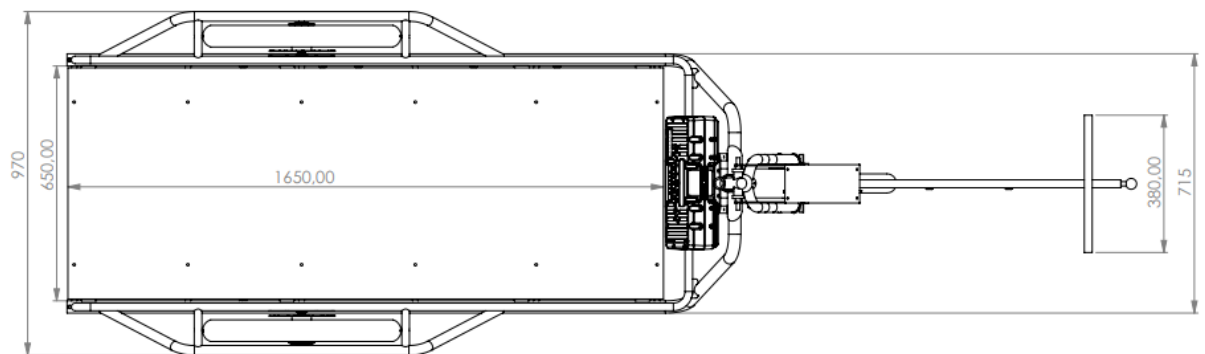

4. TECHNICAL INFORMATION

- Subject to technical changes.
- Colors and attachments may differ from photos and descriptions.
- Approved as bicycle trailer according to German law (StVZO)
- 2 years warranty on frame and attachments (except wear parts)
- In combination with a bicycle approved as pedelec according to the European standard DIN EN 15194, if applicable.

Construction according to:

- Machinery Directive: 2006/42/EG
 - EMC Directive: 2014/30/EU
 - Low Voltage Directive: 2014/35/EU
-
- Latest update: 28.07.2021

Description	Model year
CARLA	2021
eCARLA AES	2021
eCARLA Greenpack	2021